

LEITZ LABORLUX 11 POL

Students' and laboratory microscope



Instructions



1. Introduction

The LEITZ LABORLUX[®] 11 POL is a microscope for methods of investigation in polarised transmitted and incident light.

Because of the modular principle its design is based on, the following microscopic methods can be used with simply exchanged accessories:

Transmitted light

brightfield

brightfield polarised light

darkground

Incident light

brightfield

brightfield polarised light

interference contrast R

fluorescence

reflection photometry

photomicrography

television microscopy

Contents

1. Introduction	2
2. Unpacking and setting up the microscope	4
3. Technical details	5
4. Assembly of the microscope for transmitted light	14
Preparing the microscope for operation	16
Investigation of birefringent objects in the orthoscopic beam	22
Investigation of birefringent objects in the conoscopic beam	28
5. Incident-light set-up	30
Assembly of the microscope for incident light	32
Preparing the microscope for operation	35
6. Microscopic measurement	36
7. Fault tracing	36
8. Accessories	37
9. Maintenance and cleaning	38

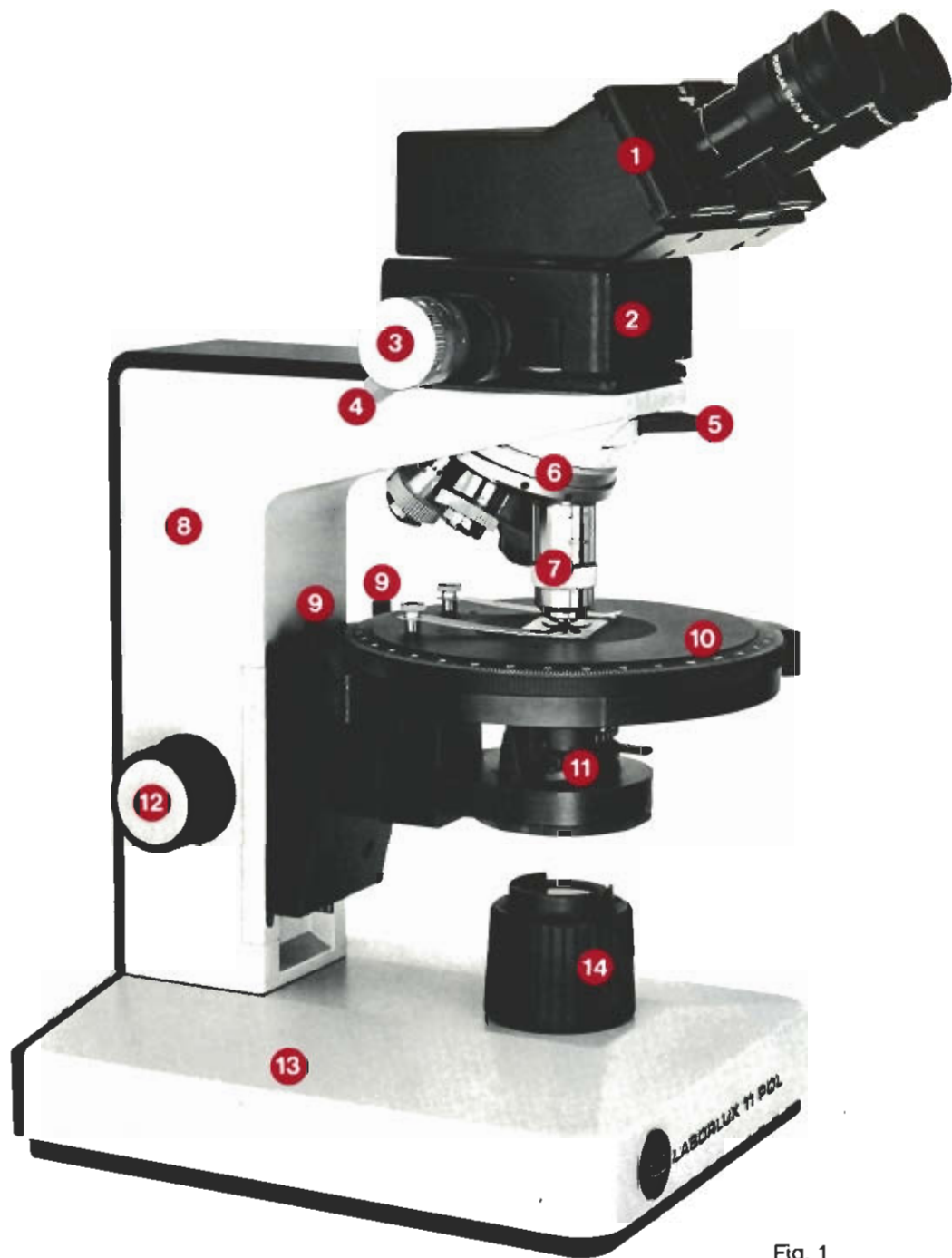

Fig. 1

2. Unpacking and assembly of the microscope

Fig. 1 LABORLUX 11 POL

- 1 Binocular pol-tube S with two PERIPLAN 10x/18 eyepieces
- 2 Intermediate tube 360
- 3 Disengageable analyser, rotatable through 360°, with 1/10° verniers
- 4 Knurled screw for immobilizing the analyser
- 5 λ -plate or empty-hole slide
- 6 Centring revolving nosepiece
- 7 Strainfree objectives for polarized-light microscopy
- 8 Microscope stand
- 9 Centring screw for the objectives
- 10 Rotary stage, mounted on ball bearings, with 360° graduation and 1/10° verniers
- 11 Polarizing condenser with built-in aperture diaphragm
- 12 Single-knob control for coarse and fine adjustment
- 13 Foot of the microscope with built-in transformer for the also built-in 6v 10W tungsten-halogen lamp
- 14 Illuminating tube with mount for 32mm dia. filters

2.1 Compare the equipment carefully with the packing note and the delivery note.

2.2 Location

Ensure that the environment of the chosen site is free from oil or chemical fumes. Vibrations, direct sunlight and considerable temperature fluctuations interfere with measurement and photomicrography. A sturdy instrument table (with drawers for the accessories) from the Leitz range is an ideal support for the microscope. Combined with an ergonomically designed adjustable seat this is essential to relaxed microscopy.



Fig. 2 Voltage selector and fuses (T125 mA) are mounted on the underside of the foot of the microscope.

3. Technical details

Electrical connection

The installation of a multiple socket for the convenient connection of microscope illumination and accessories is recommended. First compare the mains voltage with the setting of the voltage selector in the foot of the stand (Fig. 2). Only now connect the instrument to the mains.

If the plug has to be changed, the following colour code of the wires should be observed:

yellow-green = earth
black = phase
white = neutral

Tubes for transmitted and incident light

Five different tubes, for polarised light, are available for the various purposes of the microscope.

For transmitted-light investigations the tubes are used only with the transmitted-light intermediate tube, for incident light only in conjunction with the incident-light devices.

An exception are transmitted-light specimens without a coverglass. They can be observed through the vertical illuminator and incident-light objectives with transmitted-light illumination.

Monocular Pol tube P 42/30*

With engageable pinhole stop ① and centring Bertrand lens ②.

* The designation 42/30 means: 42 is the diameter of the tube changer in mm, 30 the viewing angle of the tube in degrees.

Fig. 3

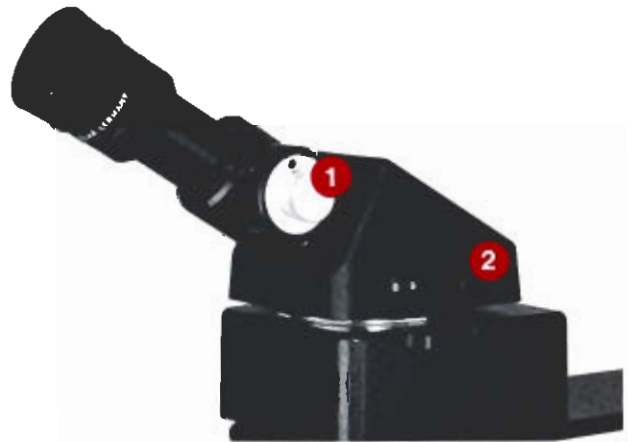



Fig. 4

Binocular Pol tube S 42/30

With adjustment facility of the two eyepieces for the individual interpupillary distance of the user.

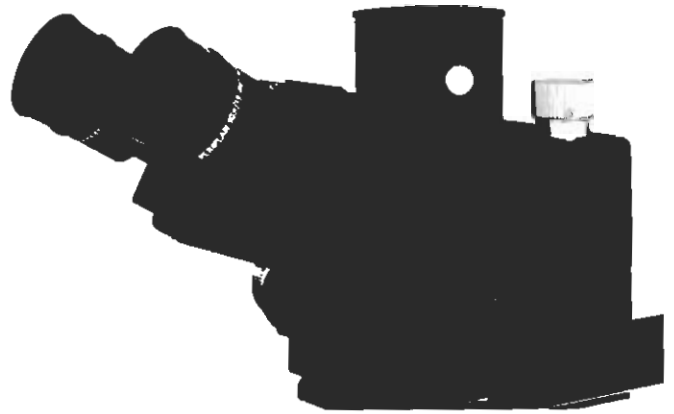

Fig. 5

Binocular pol phototubes FSA 42/30 and FSA 42/30 R

For binocular observation and for photomicrography, with adjustable beam-splitter:

- 100% of the light reach the eyepieces;
- ↑ 90% of the light reach the phototube,
10% the eyepieces;
- ↗ 50% of the light reach the phototube and
50% the eyepieces.

The binocular pol phototube FSA 42/30 R with fade-in device also offers the possibility of fading-in the format outlines and the measuring field of the automatic LEITZ VARIO-ORTHOMAT[®] camera system and the measuring diaphragm of the MPV-compact microscope photometer.

Monocular tube O

For photomicrography with focusing telescope (WILD MPS camera system).



Fig. 6

Intermediate tubes 90, 360 and 360 B for transmitted light

All three intermediate tubes have a disengageable analyser. The tube lens system is 1x. The intermediate optical system has been computed so that the compensator inserted in the tube slot is in the parallel beam, and therefore does not displace the image when a compensator is inserted or removed.

Intermediate tube 90

The built-in analyser ① can be disengaged. In conjunction with the tube P for monocular orthoscopy and conoscopy; with the tubes A and FSA for binocular orthoscopy.



Fig. 7

Intermediate tube 360

For binocular orthoscopy, especially for phase difference measurements according to Sénarmont with the tubes P, S, FSA and FSA R. The disengageable analyser ① can be rotated through 360°, vernier reading 1/10°. The disengageable neutral-density screen ② in the holder serves for brightness compensation when the analyser is removed from the optical path.



Fig. 8

Intermediate tube 360 B

For binocular orthoscopy and conoscopy with the tubes S, FSA and FSA R.

Like the intermediate tube 360, it has an analyser ① rotatable through 360° and a neutral-density screen ②. In addition a Bertrand lens with integrated pinhole stop ③ for conoscopy of small grains has been installed.



Fig. 9

Revolving nosepiece

The revolving nosepiece accepts four objectives, which can be individually centred. Precise internal click-stops of the nosepiece guarantee exact and lasting centration in the axis of rotation of the object stage. The objectives outside the optical path point to the limb of the microscope.



Fig. 10

Object stage

The object stage, permanently mounted on the stand, runs on ball bearings. Its external diameter is 167mm, its effective diameter 155mm. It has a 360° graduation and verniers of 1/10°. The maximum vertical adjustment with the single-knob control on both sides of the stand is 25mm. The stage clips can be individually removed for the attachment of the object guide.

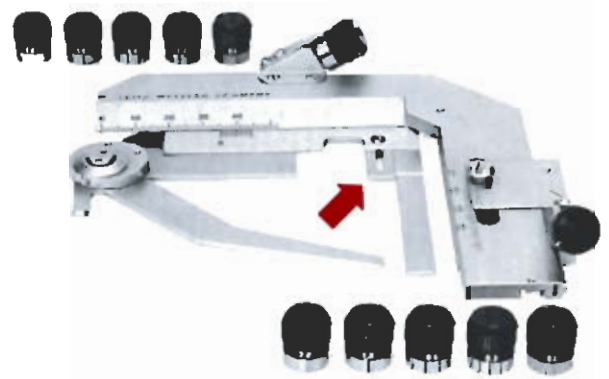

Fig. 11

Object guide

When a small lever is turned (arrow) the object guide offers the possibility of accepting microscope slides up to 50x50mm and 26x76mm size. The movement range is 30x40mm. For selective and reproducible step scanning of specimens easily exchangeable pairs of clickstop buttons (0.1 – 0.2 – 0.4 – 1.0 – 2.0mm) are available. A pair of 2mm clickstop buttons is included in the basic outfit.



Fig. 12

Polarising condenser

The aspherical condenser top AS0.90P is interchangeable in this two-lens polarising condenser with built-in aperture iris diaphragm, and permanently fixed to the object stage. The condenser top AS0.90P can be replaced by the condenser top D0.80 – D0.95 through the aperture in the object stage.

The condenser top is turned out when the aperture of the turned-in objective is < 0.25 .

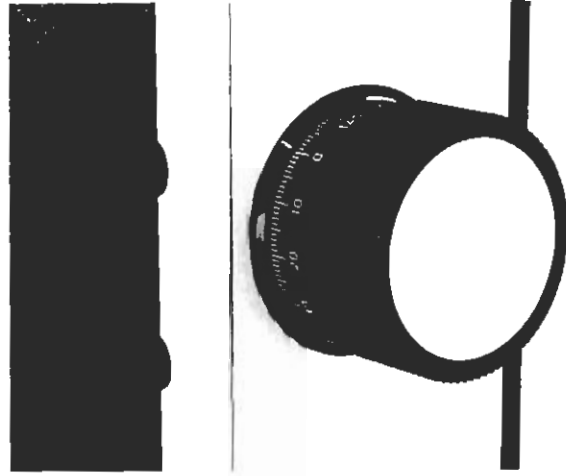

Fig. 13

Single-knob control

The coarse and fine adjustment arranged on both sides of the stand acts on the object stage. When the knobs are turned in one direction they will act as a fine adjustment for about one-third rotation, and then as coarse adjustment; when the rotation direction is reversed, the fine adjustment will again become functional. If the fine adjustment is turned beyond the slight resistance of the fine adjustment, the coarse adjustment will again be functional.

One interval of the fine adjustment corresponds to $2.3 \mu\text{m}$.



Fig. 14

Illumination

The 6v 10W tungsten halogen lamp for transmitted light illumination is housed in the foot of the stand together with the transformer. Brightness is regulated with the knurled knob on the side.

The lamp need not be centred even after exchange, because the mount is already centred.

The illuminating tube (1.14) is provided for the introduction of filters of 32mm dia. above the dust glass.

The use of filters

For transmitted-light microscopy the filters are placed on the light exit (1.14) of the foot of the stand; for incident light, they are pushed into the filter slot (41.1) of the vertical illuminator.

The following filters, among others, are examples of those available as accessories:

Diffusion disc

Used for even illumination, especially at low power.

Neutral-density filter N

Used for the attenuation of the lighting intensity with maintenance of the colour temperature. The engraved value N4 indicates the transmission in percent, for instance 100:4 = 25% transmission.

Green filter

For the improvement of picture quality in black-and-white photomicrography.

Blue filter CB 16.5

For the conversion of the spectrum of incandescent light into a daylight-like spectrum (transformer set at full power).

Interference filters

For the spectral isolation of a narrow range of wavelengths, for instance the interference line filter IL 546nm. Uses: phase difference measurements with compensator; contrasty reproduction of interference figures in conoscopy. The silvered area of the interference filter must always point towards the light source.



Fig. 15 Transmitted- and incident-light objective

Objectives

All Leitz microscope objectives computed for 160mm tube length can be used in transmitted light.

The engraved details on the transmitted-light objective (Fig. 15) contain the following information:

160 is the mechanical tube length in millimetres for which the objective is computed. It is the distance between the screw-on flange of the objective and the upper tube rim (eyepiece tube).

0.17 indicates the thickness of the coverglass. Only specimens under a coverglass (thickness 0.17mm) should be observed through these objectives.

EF objectives produce an outstandingly flat field, and excellent contrast, and are of high resolving power. This also applies to **PL** objectives.

NPL-FLUOTAR objectives additionally have superior colour correction. They are particularly recommended for photomicrography in colour.

63 is the reproduction ratio, i.e. the ratio of a line in the intermediate image to the corresponding line in the object (for instance 63:1).

0.85 is the numerical aperture.

P indicates strain-free objectives.

OIL indicates the immersion medium to be used with this objective.

Colour coding to DIN see Table on p. 13. Oil immersion objectives have an additional black ring.

The designation on the incident-light objective (Fig. 15) indicates:

∞ mechanical tube length, infinity with incident-light objectives.

/0 thickness of the coverglass = 0, i.e. objects must not be covered with a coverglass.

/30 adjustment length (30mm).

NPL normal plano objectives giving a flat field of at least 18mm diameter in the intermediate image plane.

20x/ reproduction ratio: the dimensional ratio of the microscopic intermediate image and the object (for instance 20:1).

/0.40 numerical aperture.

P strain-free objectives for polarised light.

LL objectives of very long free working distance.

Oil immersion

Oil immersion objectives are distinguished by the engraving **OIL** and a black ring round the lower rim of the objective mount. The working distance of an immersion objective is usually very short. Special care is therefore indicated during work with oil immersion objectives.

Immersing the specimen

Use only Leitz immersion oil. Ensure that the immersion oil is free from air bubbles (do not shake the bottle).

Lower the object stage or turn the objective out of the optical path and apply one to two drops of immersion oil to the specimen. Raise the object stage and focus the specimen. After the examination remove the oil as soon as possible to avoid transfer to the other objectives.



Fig. 16 PERIPLAN 10x/18 $\overline{6d}$ eyepiece

10x eyepiece magnification

/18 field-of-view index

$\overline{6d}$ high-point eyepiece for both spectacle wearers and users of normal eyesight

Annular colour code of the reproduction ratio of the objectives:

Magnif. range	1.6:1	2.5:1	4:1	10:1
Colour code	grey	brown	red	yellow

16:1	25:1	40:1	63:1	100:1
20:1	32:1	50:1		125:1
bright green	dark green	bright blue	dark blue	white

Eyepieces

For transmitted and incident light Leitz eyepieces computed for a mechanical tube length of 160mm are used in the tubes. These eyepieces can be recognised by the additional engraving of the field-of-view index 18 after the magnification: 10x/18.

The field of view is the area of the intermediate image that can be seen through the eyepiece. It will appear magnified by the eyepiece factor. The microscopic image in a 10x/18 eyepiece, for instance, appears as large as an area of 180mm dia. viewed from a distance of 250mm. For investigations in polarised light an eyepiece with orientated crosslines and horizontal graduation (length measurements see p. 36) is used. The axes of the crosslines indicate the vibration directions of the polarisers and of the object respectively.

Object field diameter

Division of the diameter of the field of view (18) by the objective magnification results in the true diameter of the object field observed.

With the 10x/18 eyepiece and a 4:1 objective, for instance, an object area of

$$\frac{18}{4} = 4.5\text{mm dia.}$$

is observed.

Final magnification of the microscope

The final magnification is the product of the reproduction ratio of the objective and the eyepiece magnification.

Example: objective 25/0.50

eyepiece 10/18

$25 \times 10 = 250\text{x}$ final magnification.

4. Assembly of the microscope for transmitted light

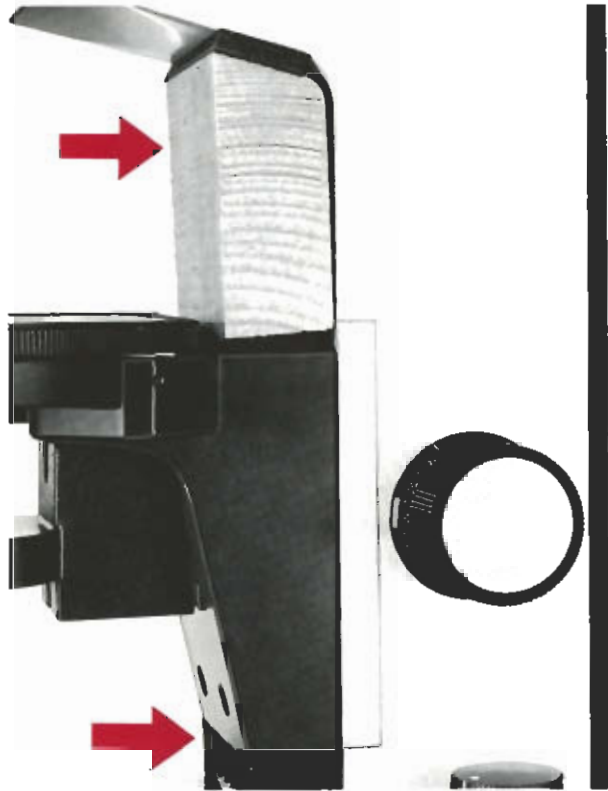

Fig. 17

Remove transport anchorage blocks (arrows). Replace them for any future transport to avoid damage.



Fig. 18

Inserting the intermediate tube for transmitted-light observation

Remove the protective cap of the tube lens system. Push the lever in the direction of the arrow and place the tube straight into the changer. Ensure that the locating pin engages in the recess of the changer. Allow the lever to slide forward. Additionally clamp the intermediate tube by slightly tightening the lever.



Fig. 19

Inserting the Pol tube

Push the lever on the intermediate tube back and place the tube straight into the changer. Ensure correct engagement of the pin.

Additionally clamp the observation tube by slightly tightening the lever.

Insert the eyepiece(s).

The eyepiece with crosslines and graduation is inserted in the right-hand observation tube of the binocular tubes. Ensure that the eyepiece engages in one of the two grooves 0° and 45° orientation. The eyepiece without crosslines is inserted in the left-hand eyepiece.



Fig. 20

Screwing-in of the objectives

Lower the object stage and screw the objectives into the revolving nosepiece in the order of ascending magnification. For transmitted light use only objectives of tube length 160mm.

Exception:

When thin polished sections without coverglass are to be examined incident-light objectives of tube length ∞ can be used, but only in conjunction with a vertical illuminator instead of an intermediate tube.

Turn the objective sleeve ① so that the text points towards you.

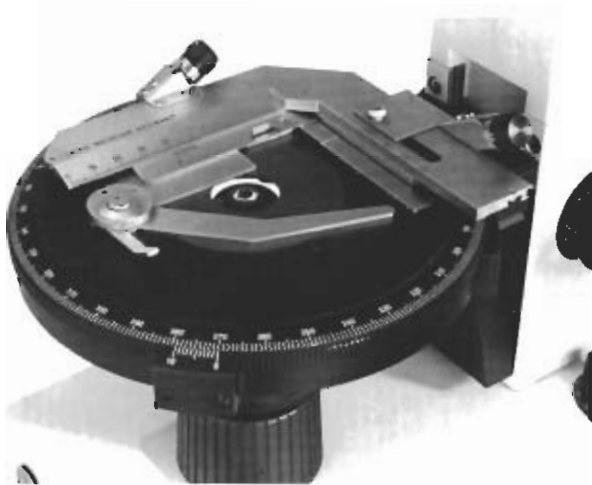

Fig. 21

Screwing-in of a condenser top

Take out the stage insert. Screw in the condenser top.

Fig. 22



Stage clips – object guide

Insert two stage clips in the object stage or screw the pol-object guide onto it with a coin.



Fig. 25

Tube setting – binocular –

Set the crosslines as described on p. 17 and insert the eyepiece in the **right-hand** eyepiece tube. Close your left eye and focus the specimen with the coarse and fine adjustment with your right eye. Close your right eye and observe the image with your left eye. Adjust the focusing eyelens of the left-hand eyepiece to focus this image too. The coarse and fine adjustment must not be operated now.



Fig. 26

Adjust the **interpupillary distance** of the tube by pushing the eyepiece tubes together or pulling them apart, until only one image can be seen with both eyes.

If necessary, readjust the left-hand eyelens.

With the FSA and FSAR tubes the optical path can be adjusted through a splitter so that sufficient light reaches the eyepieces (cf. Fig. 5, p. 6).

- 100% of the light reach the eyepieces
- ↑ 90% of the light reach the phototube,
10% the eyepieces
- ↗ 50% of the light reach the phototube, and
50% the eyepieces.
(Position for fade-in of format outlines.)

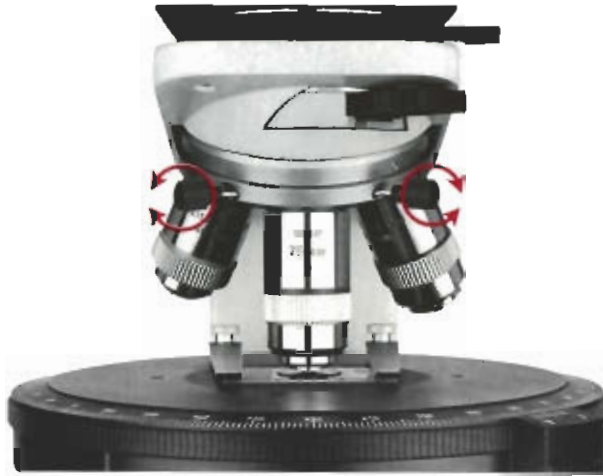

Fig. 27

Centring the objectives

For centring, the objectives are adjusted with the aid of two Allen keys (1.9), until the optical axis of the objective (and therefore the centre of the image) coincides with the axis of rotation of the object stage. With correct centration, a lined-up area of the specimen does not drift from the field of view as the stage is being rotated. An object point in the centre of the crosslines therefore does not change its position during a full rotation of the stage.

It is best to use a detail-rich, contrasty specimen for centring objectives. Narrow the aperture diaphragm (1.11) in the condenser. Turn out the analyser (1.3), pinhole stop (3.2), and Bertrand lens (3.2).

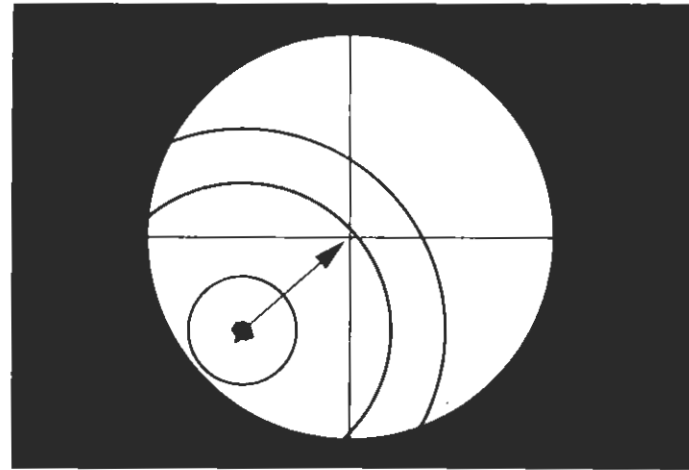

Fig. 28

Two similar methods exist for objective centration.

1. Insert the objective centring key in the apertures above the objective to be centred. Rotate the object stage and note the area of the object which does not move on a circular orbit. This object point corresponds to the mechanical axis of rotation of the object stage.

The previously determined object point must now be moved into the centre of the crosslines by means of the two centring screws. If necessary rotate the object stage and improve centration (Fig. 28).

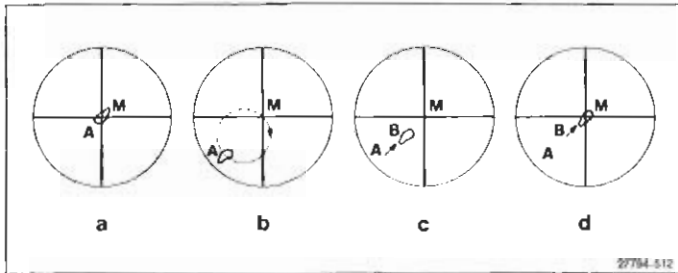
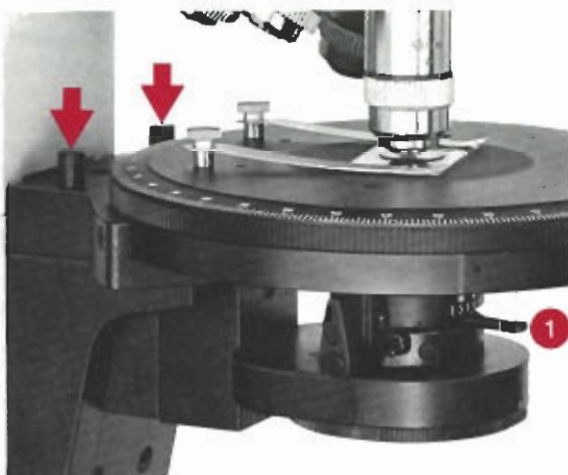

Fig. 29

2. Move a prominent area of the object A into the centre of the crosslines M. Rotate the object stage until the area of the object is at its maximum distance from the centre of the crosslines M (position A, Fig. 29). In an extreme case the point A (maximum deflection of the object area) may even be outside the field of view.

Fig. 30 Storage of the centring screws



Insert both centring screws into the apertures above the objective used. Move the microscopic image by turning the centring screws so that the object area A is in the centre (position B) of the line between the farthest position A and crosslines M. Adjust the object manually or with the aid of the attachable object guide until the prominent area is in the centre of the crosslines M. Rotate the object stage and check whether the axis of rotation of the stage coincides with the centre of the crosslines in the eyepiece. Repeat centration if necessary. If the objective is not removed, centration is preserved.

Centring the Bertrand lens

Insert the centring screws (Fig. 30, arrows) in the centring apertures of the intermediate or of the monocular tube. Turn in Bertrand lens (8.3 or 24.2), disengage the analyser (8.1). Centre the bright circular patch to the crosslines. Keep the centring screws in the two bores of the stage angle bracket.

Crossing the polariser and analyser

Find an empty area in the specimen or remove the specimen from the optical path. Turn in a dry objective of high magnification, for instance 40:1 or 63:1. Set lamp at maximum brightness. Open the aperture diaphragm (1.11). Turn in the condenser top. Insert the analyser (1.3).

With a rotatable analyser temporarily slacken the clamping screw (1.4) on the back and set the position exactly at 90° . Turn in the Bertrand lens (8.3 or 3.2).



Fig. 31 Dust protection slide

If necessary slightly pull the compensator out of the tube slot. If it is not used, it need not be fully pulled out of the tube slot. It is sufficient if it unblocks the optical path for normal observation. The compensator thus protects the tube lens against dirt.

If the compensator is pulled out, the slot should be closed with the dust protection slide (Fig. 31).

Rotate the polariser (Fig. 57.6) through the zero position until a symmetrical, blurred cross in the eyepiece indicates the exactly crossed position of the polarisers (Fig. 32).

Fig. 32 Exact crossed position of the polarisers

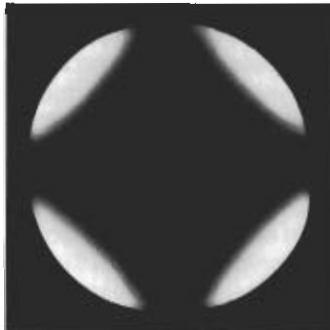
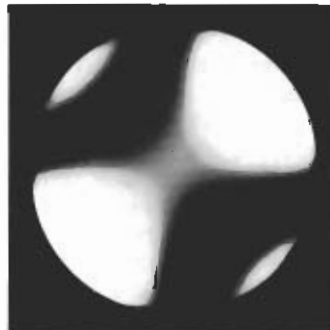

Fig. 33 Polarisers not exactly crossed



Turn out the Bertrand lens.

In microscopes without Bertrand lens it is best to remove one eyepiece for adjustment. The blurred cross will then become visible inside the tube (observation from about 10 to 25cm distance).

Setting the condenser – Koehler's illumination

The condenser top S1.1 can be used only for microscope slides of up to 1.2mm thickness.

It must be turned out when objectives of N.A. < 0.25 , such as the EF4/0.12P objective, are used.

The aperture diaphragm

The aperture diaphragm in the condenser (1.11) influences resolution, contrast, and depth of field of the microscopic image. Optimum resolution is achieved when the apertures of the objective and of the condenser are the same. When the aperture diaphragm is closed resolution decreases, but depth of field and contrast increase. When it is closed beyond about 1/3 of the aperture of the objective the resolving power is noticeably reduced.

(When the analyser is turned out and the Bertrand lens turned in, the objective aperture will appear as a slightly brighter circular area).

In polarised-light microscopes the aperture diaphragm is set for orthoscopic observation so that the contrast is as high as possible. With conoscopic observation, on the other hand, the aperture diaphragm must always be fully opened.

Important

The aperture diaphragm does not serve for the adjustment of image brightness. For this purpose, only the transformer adjustment or neutral-density screens must be used.

Investigation of birefringent objects in the orthoscopic beam

Thin polished section of rock (granite, crossed polarisers).



Orthoscopy is the normal observation of the magnified image of the object in a polarising microscope. Conoscopy or observation in a divergent or a convergent beam is the investigation of the interference image produced in the rear focal plane of the objective. This interference image is as a rule viewed through the Bertrand lens turned into the optical path and through the ordinary eyepiece. Here, the Bertrand lens takes over the function of an objective and together with the eyepiece forms a microscope, which permits the observation of the magnified interference figure (Fig. 39).

Birefringent objects (except when cut vertically to an optical axis) appear dark (normal positions) when the object stage is rotated through 90° , and bright or coloured in the intermediate regions (diagonal positions).

Isotropic objects (as well as empty areas and birefringent objects cut vertically to an optical axis) on the other hand do not exhibit intensity differences when the object stage is rotated.

Causes of the alternate extinction and reappearance of the interference colours are:

Birefringent objects (except in the direction to a crystal optical axis in which the object exhibits isotropy) divide the light into two beams vibrating vertically to each other. In one fibre, for instance, one beam vibrates parallel, the other transversely to the longitudinal axis.

Extinction position will occur when both beams vibrate parallel to the transmission directions of the polarisers.

Brightness (interference colour) will occur when both rays vibrate diagonally to the transmission direction of the polarisers. Both rays have different velocities of propagation, i.e. two different refractive indices. The higher refractive index is always called n_{γ}' , the lower one with n_{α}' . The magnitude of these refractive indices changes with the transmission direction in the specimen. In the direction of an optical axis both refractive indices are identical; the object therefore appears isotropic. The maximum values of the two refractive indices are called n_{γ} and n_{α} , the corresponding birefringence will be:

$$\Delta n = n_{\gamma} - n_{\alpha}$$

The spatial distribution of the refractive indices and of the vibration directions is demonstrated in a three-dimensional model, the so-called indicatrix. For details, special textbooks on polarised light microscopy should be consulted. See also Leitz brochure 550–51 "Polarised-light microscopy".

The differential velocity of propagation of both rays causes a phase difference Γ , which depends both on the magnitude of the effective birefringence Δn , and on the thickness d of the object:

$$\Gamma = d \cdot \Delta n.$$

After passing through the analyser both rays will interfere. Depending on the degree of the phase difference Γ produced in the specimen, a specific interference or polarising colour will appear, which can be obtained from the table on the right.

Interference colours are divided into orders. The unit chosen for this is the wave length 551nm, which corresponds roughly to the brightest point in the solar spectrum. First-order colours correspond to a phase difference of 0–551nm, second-order colours from 552–1102nm etc. With some practice, the magnitude of the phase difference can already be estimated from the interference colours.

With ascending orders the interference colours become increasingly paler and merge into the so-called "higher-order white". Adjustable compensators – see p. 26 – serve for the precision measurement of the phase differences.

first order	200	black lavender grey grey blue
	400	yellowish white vivid yellow
second order	600	red orange deep red indigo sky blue greenish blue
	800	bright green pure yellow
	1000	orange red
	1200	dark violet red indigo
third order	1400	greenish blue sea green
	1600	greenish yellow flesh-coloured carmine red
fourth order	1800	matt purple grey blue bluish green
	2000 (nm)	bright greenish grey whitish grey flesh red

Fig. 34
Table of the first- to fourth-order interference colours.

The sequences of the interference colours up to fourth order can be observed by the adjustment of the quartz wedge (Fig. 36) or of the tilting compensator (Fig. 38). For this purpose the quartz wedge or the tilting compensator is inserted in the tube slot (1.5). For observation the Bertrand lens can be additionally inserted in the optical path.

The use of $\lambda/4$ - and λ -plates

The vibration directions γ' and α' , which correspond to the rays of refractive indices $n_{\gamma'}$ and $n_{\alpha'}$ as well as the angle which they include with cleavages, crystal faces etc., are frequently of interest. The vibration directions can be determined by the insertion of an auxiliary object (compensator) in one of the tube slots of the microscope. If the vibration directions of the object $n_{\gamma'}$ and compensator n_{γ} corresponding to the higher refractive index are parallel to each other, the total phase difference in the microscope will increase, and a "higher" interference colour is seen. But if the two vibration directions corresponding to the rays of the higher refractive indices are vertical to each other (Fig. 35) the phase difference will decrease. The vibration direction of the compensator is marked on the mount with a line or arrow (Fig. 36).

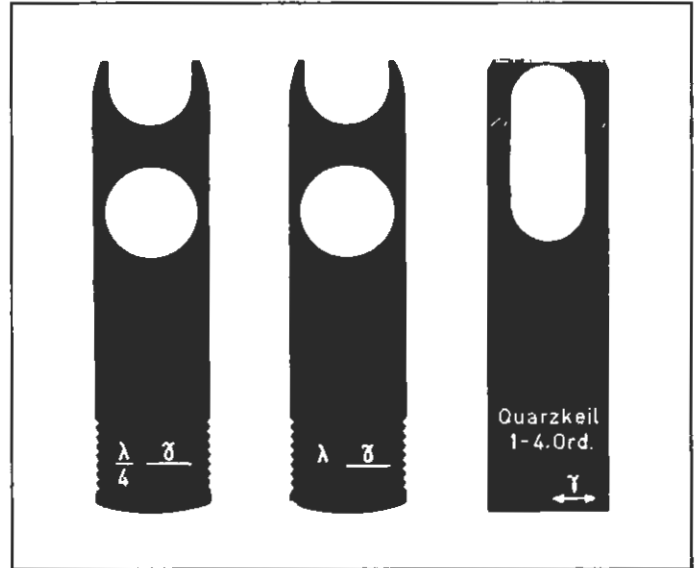

Fig. 36 $\lambda/4$ - and λ -compensator and quartz wedge first to fourth order

Fig. 35 a and b addition position
c and d subtraction position

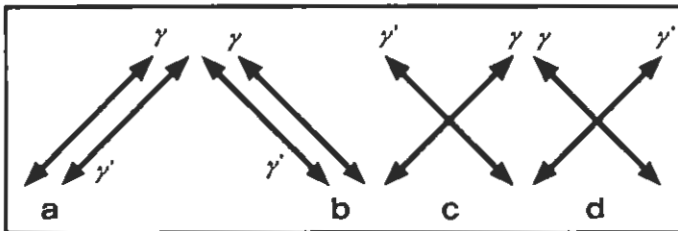

Fig. 37 λ -plate in subparallel position



Example 1:

An object exhibits the interference colour vivid yellow of first order (see table). After insertion of the $\lambda/4$ -plate (phase difference about 137nm) in the tube slot of the microscope the object will appear red-orange. The phase difference, therefore, has increased as the table shows:

The vibration direction γ' (specimen) is parallel to the vibration direction γ : Fig. 35a.

Example 2:

Interference colour of the object: grey-blue, with λ -plate sky blue.

The phase difference has therefore increased: γ' (specimen) is parallel to γ (compensator) Fig. 35a.

Example 3:

Interference colour of the object: vivid yellow; with $\lambda/4$ -plate: yellowish-white.

The phase difference has decreased: γ' (specimen) is vertical to γ (compensator), Fig. 35b.

Instead of the two fixed compensators the quartz wedge (Fig. 36) and tilting compensator (Fig. 37) can be used for these determinations. The choice of the compensator depends on which of them produces the clear-cut results.

Use of the λ -plate in subparallel position

This compensator serves for the detection of very weak birefringence ($\Gamma < 20\text{nm}$) and for the determination of the vibration directions γ' and α' in weakly birefringent objects. The vibration direction γ of the rotatable λ -plate is parallel to the transmission direction of the polariser (east-west) when the two red dots coincide. After slight clockwise or anti-clockwise rotation of this plate from its normal position object areas of very small phase difference will become prominent by a colour shift towards blue (addition) or yellow (subtraction). Because the orientation of the λ -plate is known according to the subsequent rotation (WSW-ENE or WNW-ESE) the vibration direction γ in weakly birefringent objects can be determined as with the use of the λ - and $\lambda/4$ -plate (Fig. 35).

Use in incident light is also possible.

References: LAVES F. und Th. ERNST: Die Sichtbarmachung des Charakters äußerst schwacher Doppelbrechungseffekte. – Naturwiss. 31, 68–69. 1943.

SCHMIDT, W. J.: Diagonale und Subparallele Gipsplatte Rot I und verwandte Hilfsmittel in der histologischen Polarisationsmikroskopie. – Leitz-Mitteilungen Wiss. Tech. III (8). 234–243. 1967.

PATZELT, W.: Polarisationsmikroskopie; Leitz Broschüre 550–51.

Quantitative determination of phase differences through the use of compensators

Adjustable compensators serve for the exact measurement of phase differences. When the thickness of the object d is known, birefringence $\Delta n'$ can be calculated according to the following formula:

$$\Gamma = d \cdot \Delta n' \text{ [nm]}$$

For the measurement the compensator is inserted in the tube slot and adjusted until the object area to be measured is in its maximum extinction position. For this purpose the object has to be moved into a certain diagonal position. Further details are contained in the instructions for the use of the compensators.

The following compensators are available:

Elliptical compensator according to Brace-Koehler

This rotary compensator is supplied with a compensator plate of about $\lambda/10$ phase difference. Measurement is carried out in white or in monochromatic light.

Main use:

Objects of very small phase differences (biology, strained glasses).

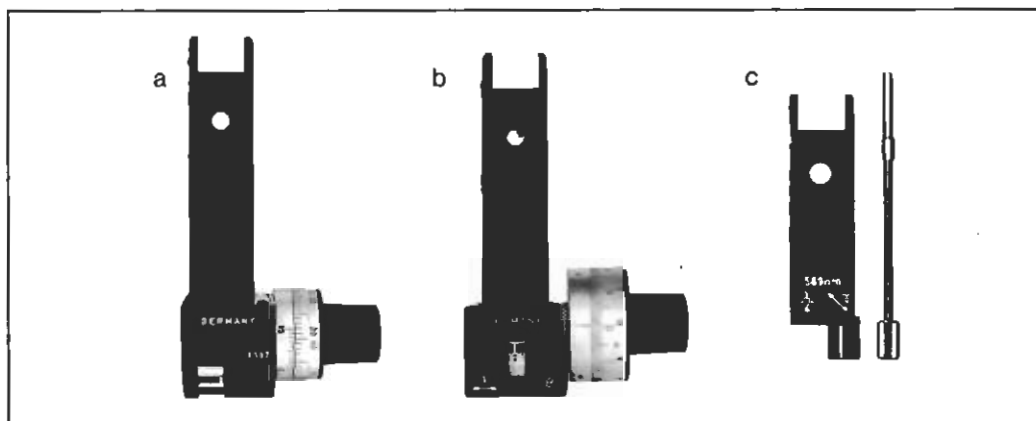

Fig. 38
Compensator according to
Brace-Koehler (a).
Tilting compensator (b).
Compensator with $\lambda/4$ -plate
in subparallel position (c)
(with adjustment screw).

**Elliptical compensator
according to Sénarmont**

($\lambda/4$ -plate in subparallel position)

Measurement is executed in monochromatic light (546nm), and the use of a rotary analyser (intermediate tube 360 or 360 B) is necessary. Normally this compensator serves for the measurement of phase differences of up to the first order, although higher phase differences, too, can be measured. The compensation, however, does not produce the entire phase difference but only the amount that is in excess of a whole wave length or of a multiple thereof. Whole wave lengths must be determined with a tilting compensator, quartz wedge, or estimation of the interference colour. Accuracy is higher than with the tilting compensator.

**Tilting compensator B
measuring range up to 5 orders**

Compensator with MgF_2 plate for measurements in monochromatic or in white light of up to 5 orders (5λ) phase difference. The phase difference can be read directly from the sum of the two angles of compensation produced when the compensator plate is tilted in both directions, from a calibration chart supplied.

**Tilting compensator E,
measuring range up to 10 orders**

Evaluation as with the tilting compensator B.

**Tilting compensator K,
measuring range up to 10 and 30 orders**

For the measurement of phase differences in white or in monochromatic light up to the maximum phase difference mentioned above. The compensator plate consists of calcite; evaluation is based on simple calculation by means of enclosed tables and the stated calibration constants.

Investigation of birefringent objects in the conoscopic beam

The optical axes of crystals are reproduced and the optical character (positive or negative birefringence) is determined in the conoscopic beam. Here the object is transilluminated in as many different directions as possible, i.e. at a large condenser aperture, and the interference image formed in the rear focal plane of the objective is observed with the Bertrand lens in the optical path. With the appropriate cutting angle of the object, the shape of the interference figure reveals whether the crystal is uniaxial or biaxial (Fig. 39). The additional use of fixed and variable compensators also allows the determination of the optical character on the basis of the shift of the interference fringes in the various quadrants and sectors of the interference figure. Details of the determination will be found in textbooks on polarised-light microscopy.

Setting the microscope for conoscopic observation

First find an object area of suitable angle of cut in the orthoscopic beam. If necessary use a low-to-medium power objective for this purpose.

The most suitable object areas for conoscopic observation are those that show the lowest possible phase differences (Table p. 23).

It is essential to perfect conoscopic observation that the objectives should be precisely centred and the polarisers precisely crossed.

Turn an objective of the highest possible aperture, for instance 40:1 or 63:1, and the condenser top into the optical path. Open the aperture diaphragm (1.11) and turn the Bertrand lens (8.3) into the optical path. In microscopes without Bertrand lens the interference figures will become visible after removal of the eyepiece. Interference figures can also be observed when the focusing telescope (Code No. 513 468) is used instead of the eyepiece.

Isolation of small grains

Turn in the pinhole stop (3.1) when using the P tube. In the intermediate tube 360 B the Bertrand lens is already coupled with a pinhole stop, which, after removal of the tube, can be unscrewed, for instance to permit cleaning of the Bertrand lens. For very small grains, it may be necessary to lower the object stage slightly (only with intermediate tube 360 B).

Determination of the optical character (Fig. 39)

Uniaxial crystals

For the determination of the optical character cutting angles are particularly suitable in which the optical axis of the crystal and that of the microscope are parallel to each other. In the orthoscopic beam, objects that are orientated accordingly show no or only very slight phase differences when the object stage is rotated. Uniaxial crystals observed in the conoscopic (divergent) beam show a dark cross, whose centre indicates the position of the optical axis. The cross is surrounded by coloured interference fringes*. When a variable compensator (quartz wedge or tilting compensator) is operated the rings drift towards the centre and outwards respectively in two opposite quadrants of the cross. The optical character is determined from the movement direction of the rings according to the following rule (Fig. 39):

* With thin objects or with objects of low birefringence only the cross will be visible.

Uniaxially positive crystals:

The movement direction of the fringes from the centre of the cross outward is vertical to the engraved γ -direction of the compensator.

Uniaxially negative crystals:

The movement direction of the fringes from the centre of the cross outward is parallel to the γ -direction of the compensator.

Cutting directions in which the optical axis of the crystal is inclined to the direction of observation are also suitable for the determination of the optical character, which can mostly be determined even when the centre of the cross is outside the field of view. Fig. 39 shows that fixed instead of variable compensators can also be used for the determination of the optical character.

Fig. 39a

Determination of the optical character of uniaxial structures.

Left: positively uniaxial crystal, cut vertically to the optical axis.

Right: negatively uniaxial crystal, cut vertically to the optical axis.

- 1 Demonstration of the vibration directions in the object and in the compensator.
- 2 Change of the interference figure when a $\lambda/4$ -plate is used.
- 3 Change in the interference figure when a λ -plate is used.

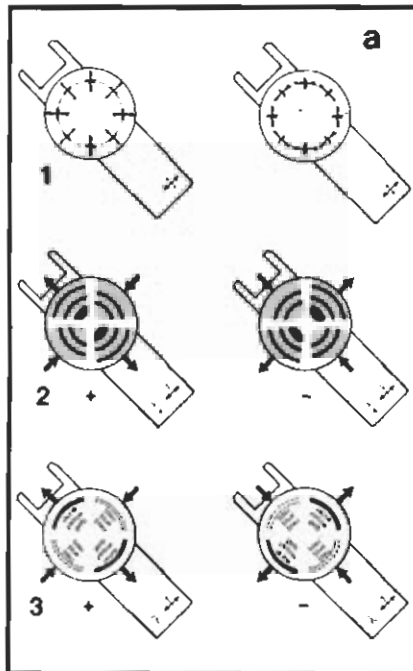

Fig. 39b

Table for the determination of the optical character.

b Orientation of the compensator plate	Uniaxial		Biaxial			
	+	-	+		-	

* With the $1/4$ - λ mica plate black dots will occur instead of the black arcs.

5. Incident-light devices

Conoscopy of biaxial crystals

For the determination of the optical character cutting directions are particularly suitable in which the bisectrix of the two optical axes is parallel to the viewing direction (section vertical to the acute bisectrix).

In the divergent beam a dark cross will be seen which opens up into the two branches of a hyperbola, the so-called isogyres, when the object stage is being rotated. The cross and the branches of the hyperbola are surrounded by interference fringes. According to Fig. 39 or the rule mentioned below the optical character can be determined from the displacement direction of these fringes after operation of the compensator. The symmetry plane of the isogyres (axial plane) must be vertical to the γ -direction of the compensator:

Biaxially positive crystals.

The interference fringes move from the convex to the concave side of the isogyres when the compensator is operated.

Biaxially negative crystals.

The interference fringes move from the concave to the convex side.

The optical character can be usually identified even when only one of the optical axes is in the viewing direction of the observer. In the parallel beam the brightness of specimens orientated in this way changes little if at all during rotation. In the divergent beam, only one of the two isogyres will then be visible.

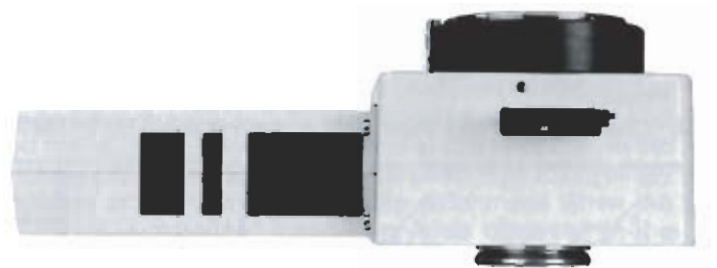

Fig. 40 Pol-vertical illuminator SR (with semi-reflecting optical-flat reflector)

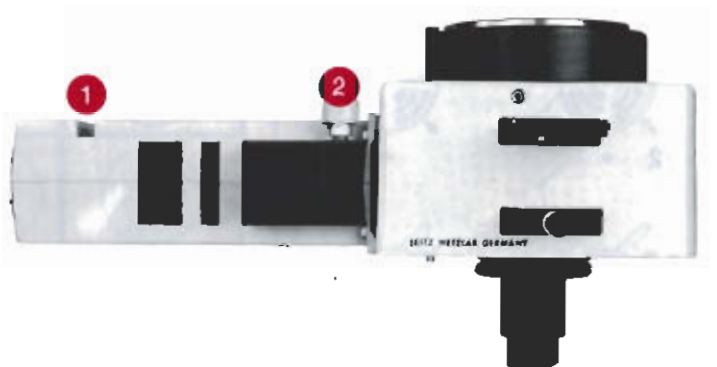

Fig. 41 Pol-vertical illuminator TR (① filter slot, ② vertical adjustment of the aperture diaphragm)

Fig. 42 LABORLUX 11 POL with SR Pol vertical illuminator

- 1 Pinhole stop
- 2 Bertrand lens
- 3 Analyser
- 4 Field diaphragm
- 5 Aperture diaphragm
- 6 Polariser
- 7 Dust slide
- 8 Objective



Fig. 43 LABORLUX 11 POL with TR Pol vertical illuminator

- 1 Analyser
- 2 Polariser



Assembly of the TR and SR Pol vertical illuminators

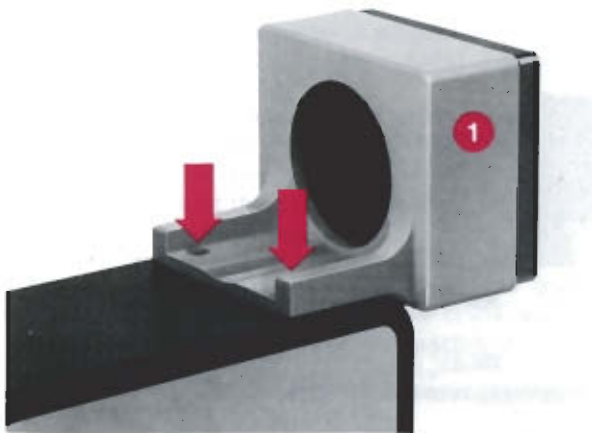

Fig. 44

Fig. 45

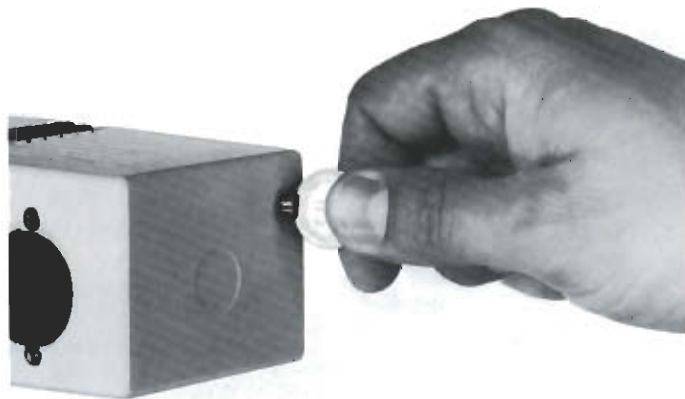
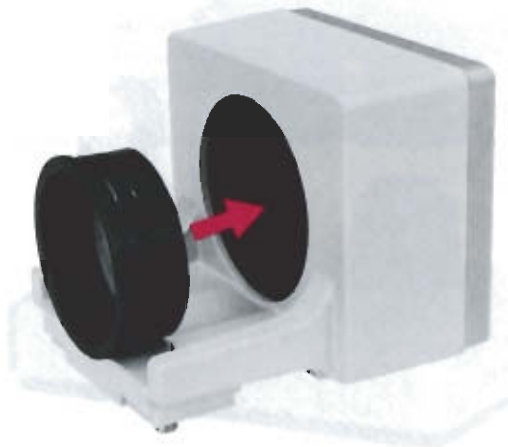

Fig. 46

Fig. 44
Remove the cover plate from the top of the stand (for instance with the aid of a paperclip), wipe the contacts with a clean cloth, insert the lamp holder ① into the aperture and screw it home.

Fig. 45
Only with the **TR** vertical illuminator with Lamp Housing 20: insert the diffusion disc.

Fig. 46
Screw the Lamp Housing 20 on to the back of the holder. Through the internal wiring the lamp is connected with the transformer built into the foot of the microscope.

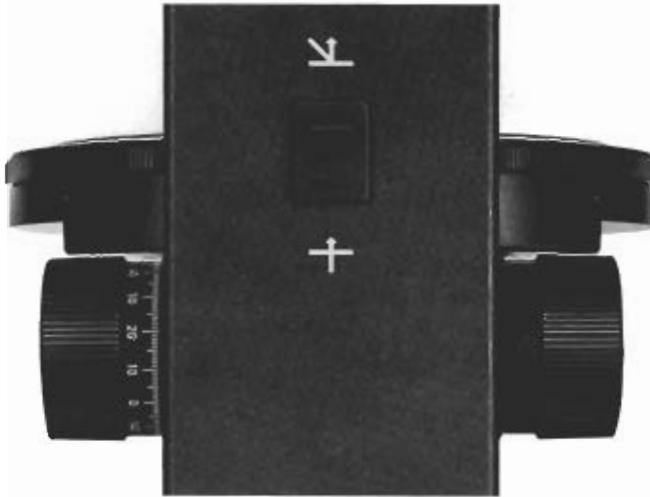

Fig. 47

Fig. 47
Turn the rocker switch (47) for incident light up. Operate the mains switch (23.4) on the back of the stand. Regulate lamp brightness (23.2).

More powerful light sources

The Lamp Housing 50 and 102Z can also be attached and locked on to the lamp holder. Both lamp housings are supplied through a separate transformer.

Attention

With lamps of more than 20W an additional heat filter must always be inserted in the lamp housing to protect the polariser.



Fig. 48 Lamp Housing 50

Fig. 49 Lamp Housing 102Z

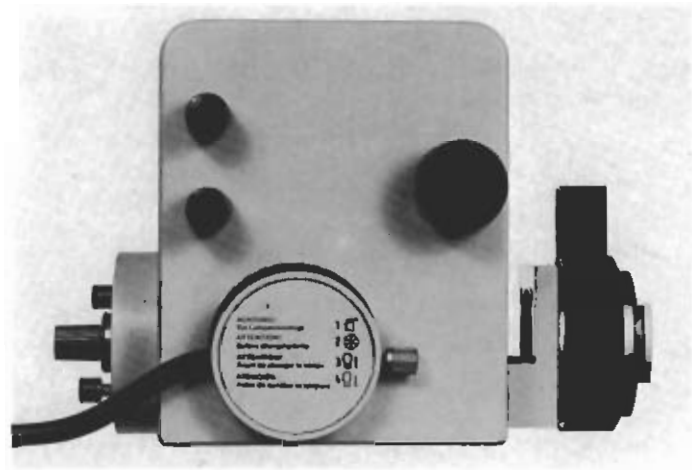

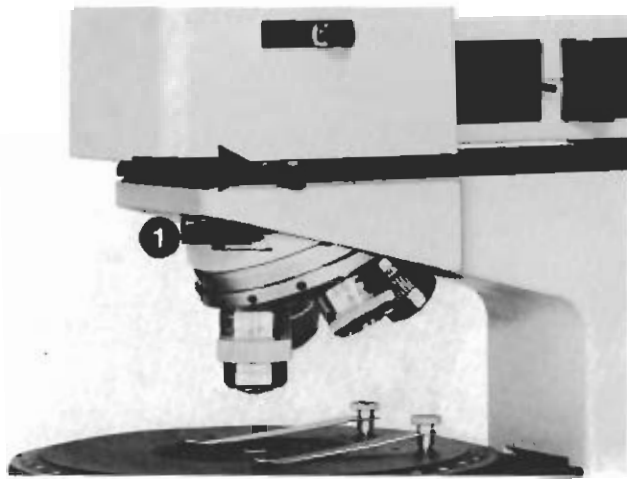

Fig. 50

Pull off the protective caps, mount the vertical illuminator and the tube on the stand and secure them. Screw the incident-light objectives into the centrable revolving nose-piece.

With SR vertical illuminator only: insert the dust slide (Fig. 50.1) in the tube slot.



Fig. 51

Inserting the neutral-density filter (accessory)

Remove the securing screw and pull out analyser.

Insert the neutral-density screen in the empty hole and secure it with the clamping ring (arrow). Replace the analyser slide.

When the analyser is disengaged, the neutral-density filter protects the eye against glare by preventing an excessive increase in lighting intensity.

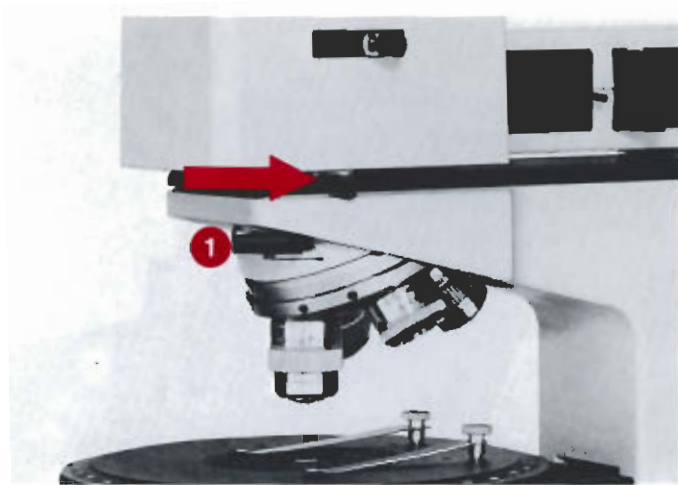

Fig. 50

Pull off the protective caps, mount the vertical illuminator and the tube on the stand and secure them. Screw the incident-light objectives into the centrable revolving nose-piece.

With SR vertical illuminator only: insert the dust slide (Fig. 50.1) in the tube slot.



Fig. 51

Inserting the neutral-density filter (accessory)

Remove the securing screw and pull out analyser.

Insert the neutral-density screen in the empty hole and secure it with the clamping ring (arrow). Replace the analyser slide.

When the analyser is disengaged, the neutral-density filter protects the eye against glare by preventing an excessive increase in lighting intensity.

Preparing the incident-light devices for operation

SR and TR pol-vertical illuminator

Switch on the illumination.

Set up the tube and eyepiece(s) (see p. 18).

Remove the Bertrand lens (3.2 and 8.3), pinhole stop (3.1) and analyser (8.1) from the optical path.

Open the aperture and field diaphragms (42.4 and 5).

Centre the objectives (see p. 19).

Cross the polarisers: push polariser and analyser in towards the right. Swivel the analyser until the object area is at maximum extinction. This adjustment cannot be carried out with specimens that exhibit bireflection. Close the field diaphragm (42.4) to the edge of the field of view and, if necessary, centre it with the centring screws (42.4).

Set the aperture diaphragm for the required contrast.

Only with

TR-pol-vertical illuminator

Vertical adjustment of the aperture diaphragm:

Turn out the polariser or analyser.

Turn in the Bertrand lens or pull out the eyepiece and, if necessary, replace it by the focusing telescope, and focus. Adjust the diameter of the aperture diaphragm, which now becomes visible as a polygon to obtain the required contrast.

Vertically adjust the aperture diaphragm with the setting knob (41.2) so that its rim touches neither the lower horizontal edge nor the upper semicircular boundary (objective pupil) (Fig. 52).

Fluorescence excitation with the 3 λ -PLOEMOPAK see special instructions.

Fig. 52 Centred aperture diaphragm (TR pol-vertical-illuminator)

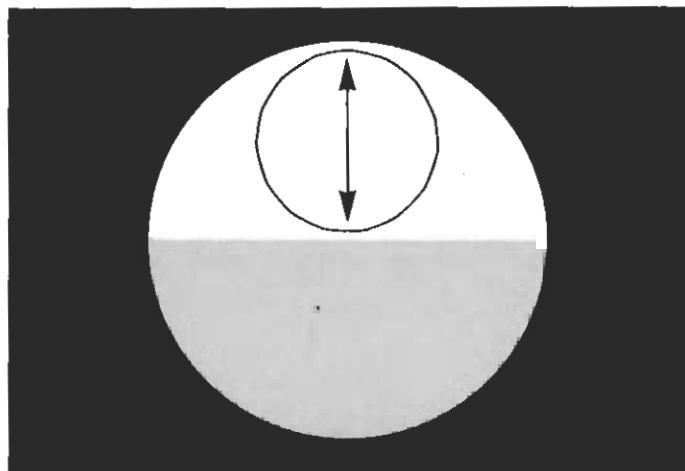

6. Microscopic measurement

Linear measurements of microscopic objects are carried out with a stage micrometer and the graduation of the eyepiece crosslines. Before measurement is begun the micrometer value of the objective used must be known. The micrometer value is the distance in the object plane of which an image is formed by the objective precisely on an interval of the crosslines scale in the micrometer eyepiece. Because the optical constants of the objectives are subject to minor fluctuations, the microscopist is advised to determine the micrometer values himself with the aid of a stage micrometer.

Example:

Determination of the micrometer value with the aid of a stage micrometer 2mm = 200 intervals and a micrometer eyepiece with graticule 10mm = 50 intervals.

Make the zero lines of the micrometer eyepiece and of the stage micrometer coincide in the microscope. The micrometer value is read with unchanged setting of the scale of the micrometer eyepiece (Fig. 53).

If 1.220mm of the stage micrometer coincides with 50 intervals of the micrometer eyepiece, the micrometer value = $1.220 : 50 = 0.0244\text{mm} = 24.4\mu\text{m}$. Only 10 intervals on the micrometer eyepiece are compared with low power objectives which do not form an image of the stage micrometer across the entire scale of the micrometer eyepiece. If, for instance, 0.36mm of the stage micrometer coincides with 10 intervals of the micrometer eyepiece, the micrometer value = $0.36 : 10 = 0.036\text{mm} = 36\mu\text{m}$. For very precise measurements under the microscope a screw micrometer eyepiece about which our list 513-17 supplies detailed information is used.

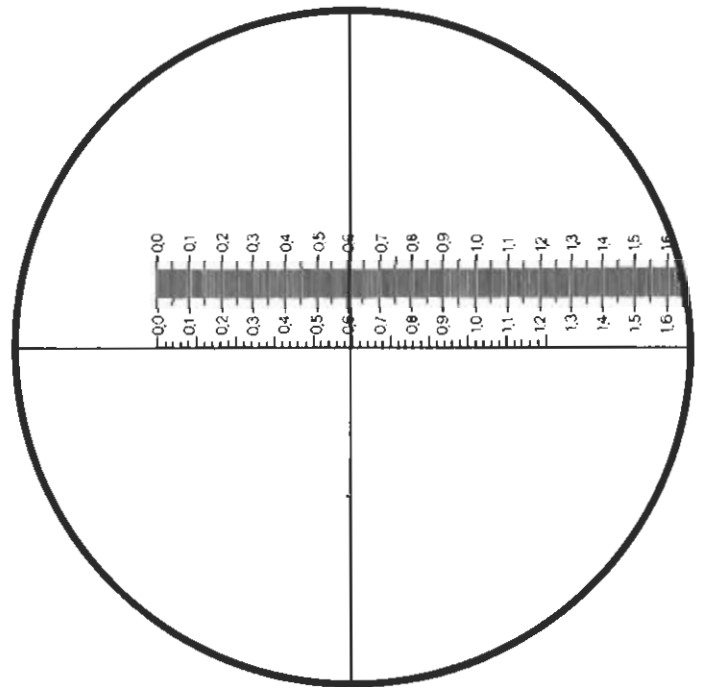

Fig. 53

Graduation of the graticule in the eyepiece and image of the stage micrometer.

7. Fault tracing

Microscope illumination does not function

Possible causes:

Mains fuse blown.

Connecting cable defective or incompletely inserted in the instrument or socket.

Rocker switch on the back left of the foot of the stand not switched on.

Rocker switch on the back of the limb not switched over.

Built-in fuse in the foot of the stand (Fig. 2) blown.

Lamp defective (Fig. 54).

Dirty contacts in the incident-light lamp holder (Fig. 44).

Poor extinction

Possible causes:

Polarisers not exactly crossed.

Polariser damaged by intense light sources (yellow discolouration).

Aperture diaphragm opened too far.

Strain in the condenser top or objective (to detect this, rotate the condenser top or objective in the mount and observe it through the Bertrand lens).

Compensator in the condenser or in the tube slot.

Optical system very dirty (check with Bertrand lens).

Unsatisfactory image quality

Possible causes:

Front of the objective or interior of the objective contaminated with oil.

Coverglass absent or too thick.

Specimen too thick or too thin.

Birefringent materials (plastics) have been used for the microscope slide, the coverglass, or the embedding medium.

Aperture diaphragm too far closed or too far open or in incident light wrongly.

Condenser top not turned in.

8. Accessories

WILD MPS microphoto system

The WILD MPS microphoto system offers the choice between various outfits for three different camera formats. Details are contained in the special Wild literature.

Tracing device

The tracing device is inserted between stand and observation tube. The microscope image is traced in the coincident-image mode: the tracing area and pen are observed simultaneously with the microscopic image in the tube. The reproduction ratio of the tracing can be continuously varied up to a factor of 2.

Recommended eyepiece: LEITZ PERIPLAN 12.5x/18

Television microscopy

Compact television cameras of up to 5 kg weight and C-mount objective change can be directly mounted through an adapter on the monocular tube 0 or on the phototubes FSA 42/30 (R).

9. Maintenance and cleaning

To protect it against dust the microscope should be covered with the flexible dust cover when not in use. The stand should be occasionally cleaned with a linen rag or chamois leather. No methylated spirit must be used, because this attacks the enamel. Benzine, however, is eminently suitable for the cleaning of enamel surfaces. Bright patches on the object stage can be rubbed off with liquid paraffin or acid-free vaseline.

Special care is indicated during investigations for which acids or other corrosive chemicals are used. Direct contact of the optical system and stand with these chemicals should be avoided in all circumstances and all components carefully cleaned after use.

The optical components of the microscope should be kept meticulously clean.

Dust on glass surfaces is best removed with a fine, dry sable brush, and light blowing across the surface as the brush is being used. If the dirt is firmly lodged, a clean cloth moistened with some distilled water should be used. If even this is ineffective, use pure methylated spirit. Immersion oil is removed with alcohol (ethanol) only.

Objectives must not be dismantled for cleaning.

All Leitz instruments have been manufactured and tested with the greatest of care according to the latest technical developments. Should you still have any complaints, please do not interfere with these instruments and their accessories. Contact your national agency or our central servicing department,

ERNST LEITZ WETZLAR GMBH

Technical Service

Technical Service Department Instruments (TSI)

P.O.B. 20 27

D-6330 Wetzlar, Germany

Telephone: 0 64 41 / 29-0 (Switchboard)

Telex: 4 83 727 ELTSC



Fig. 54

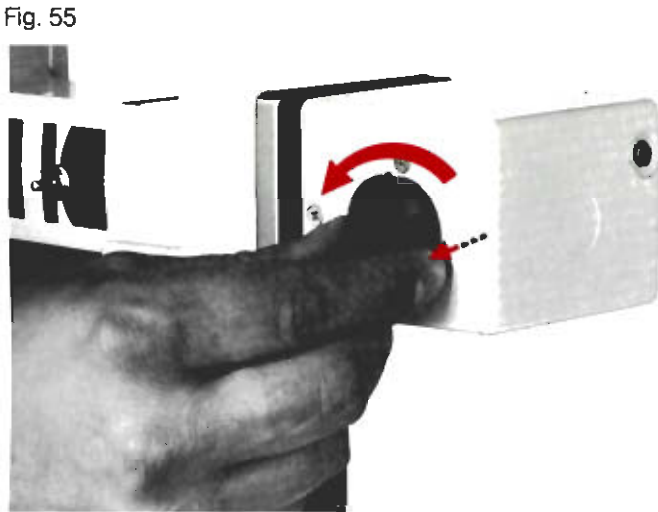



Fig. 55

Changing the 6v 10W and 6v 20W tungsten halogen lamps

Changing the 6v 10W lamp for transmitted light

 Switch off the microscope illumination or disconnect it from the mains before opening the base plate.

Tilt the microscope, open the base plate, and exchange the old lamp. To avoid fingermarks grip the new lamp in its wrapper and insert it in the socket (Fig. 54).

Changing the 6v 20W lamp for incident light (Lamp Housing 20).

Apply slight pressure to the knurled wheel of the lamp mount and turn the wheel to the left. Pull out the lamp mount (Fig. 55).

Fig. 56

Pull the old lamp out of the push-in socket. Insert the new lamp between the two clamps in the socket. To avoid fingermarks, it is essential to grip the new lamp in its wrapper. Insertion in the lamp mount centres the lamp.

Fig. 56

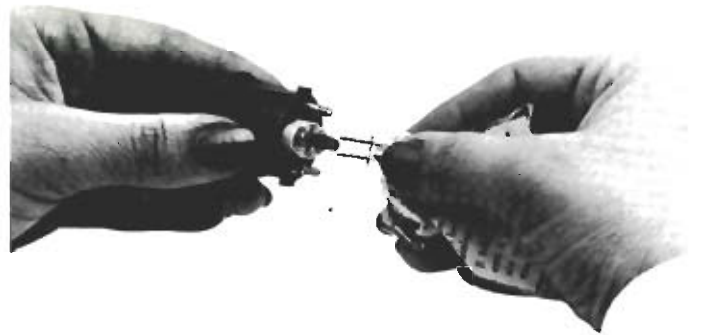

Fig. 57 LABORLUX 11 POL

- 1 Pinhole stop
- 2 Monocular Pol tube P with PERIPLAN 10x/18 eyepiece
- 3 Intermediate tube 90
- 4 λ -plate or empty hole slide
- 5 Centring keys
- 6 Condenser with built-in aperture diaphragm and rotatable polariser
- 7 Knurled knob for setting the lamp brightness





Dimensions of the microscope in mm

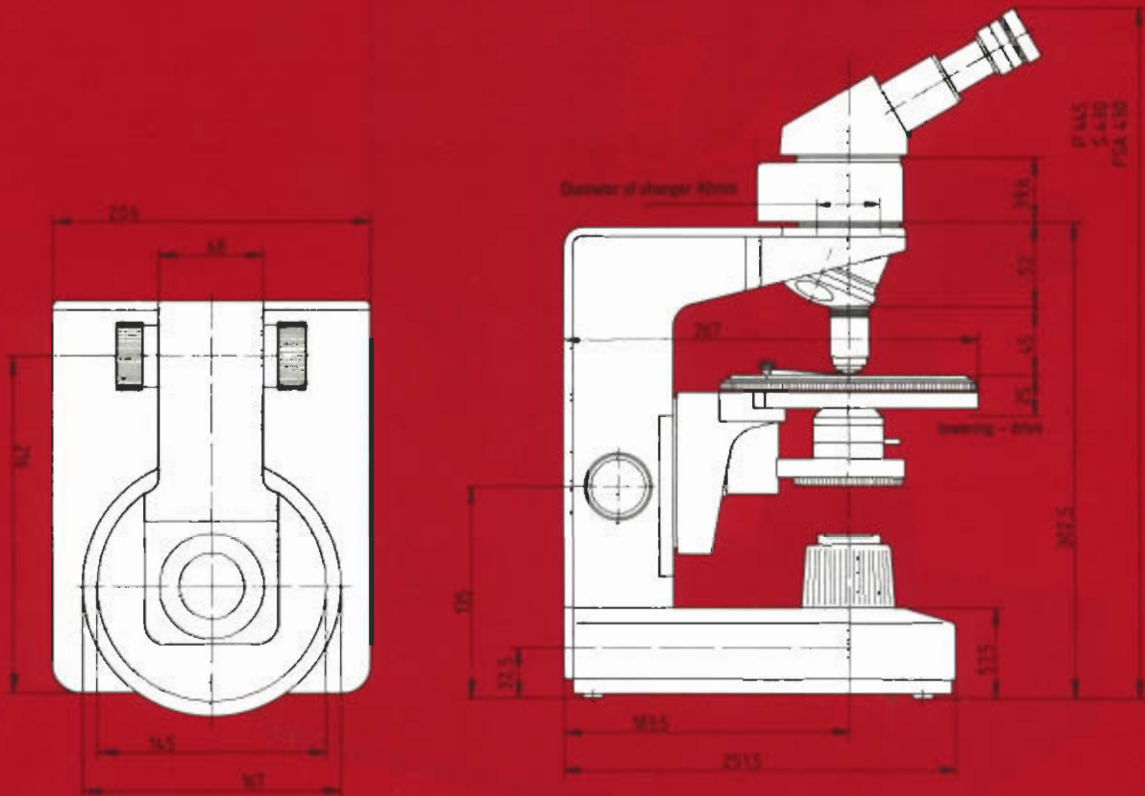

Weight of the microscope about 8.0 kg



**Leitz means precision.
World-wide.**

® — Registered Trademark
Design subject to alteration without notice.

ERNST LEITZ WETZLAR GMBH

D-6330 Wetzlar · Tel. (0 64 41) 29-0 · Telex 4 83 849 leiz d
Subsidiary: Ernst Leitz (Canada) Ltd., Midland, Ontario

Code-Nos. of the editions in
German French
933 387 933 410

Spanish
—

LEITZ WETZLAR and WILD HEERBRUGG

Two enterprises of worldwide reputation — offering the leading range in microscopy and metrology. Research, production, distribution, and service shared world-wide guarantee optimum performance of optical, precision-mechanical, and electronic systems.